

ACCUWAY

Multi-tasking

Turning Center



CE

Rigid Structure

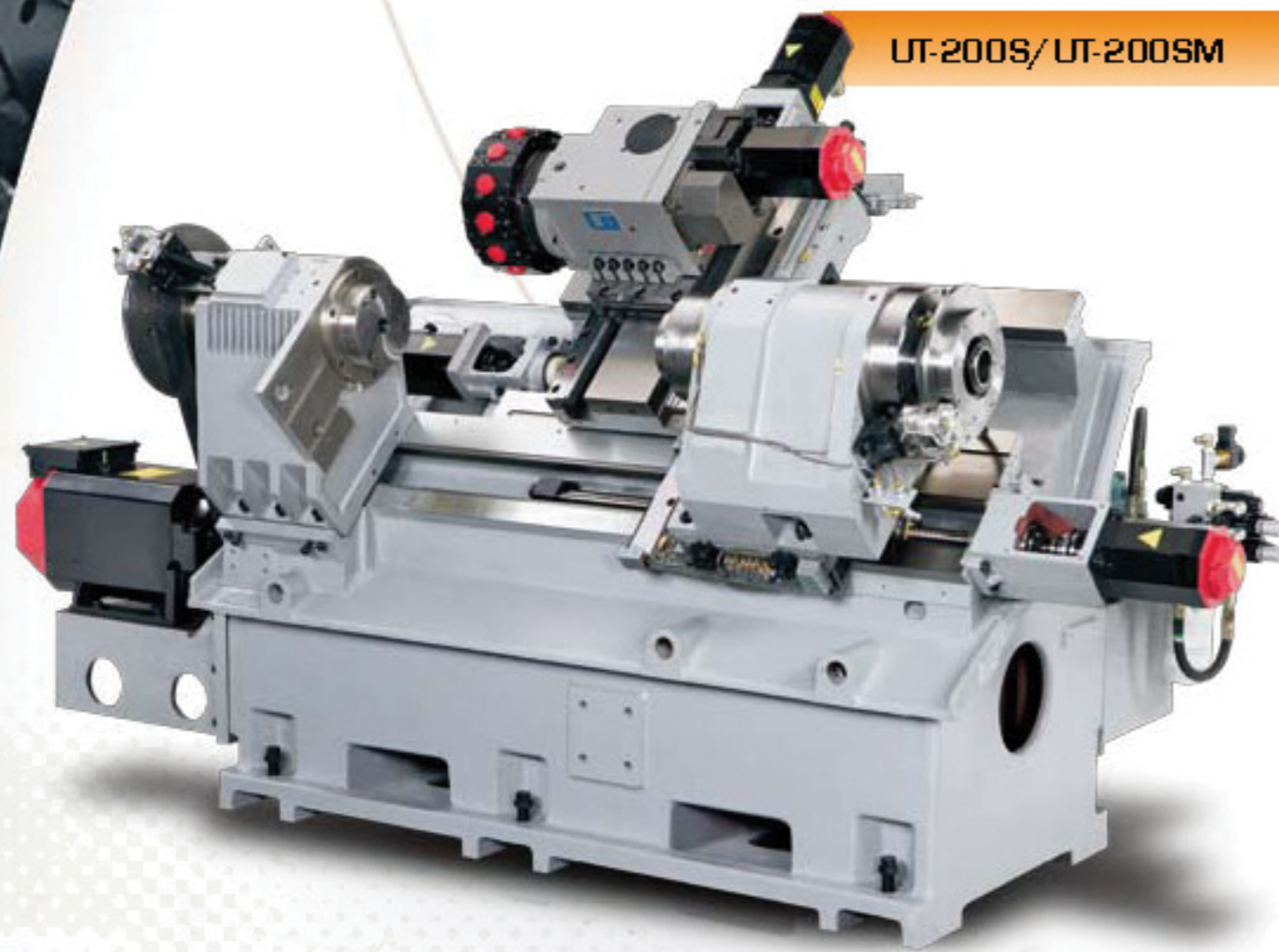

UT-200S/UT-200SM

One-piece Slant Bed Structure

- The machine bed is made of one-piece high-grade Meehanite casting to allow heavy cutting capabilities. The wide hardened and ground box ways are coated with Turcite and hand-scraped for ultra-precise fitting to reduce vibration while offering better tool life and surface finishes.
- Each axis structure is directly driven by precision ballscrew and powered by AC servo motor for smooth slide movement with virtually no backlash.

UT-300Y

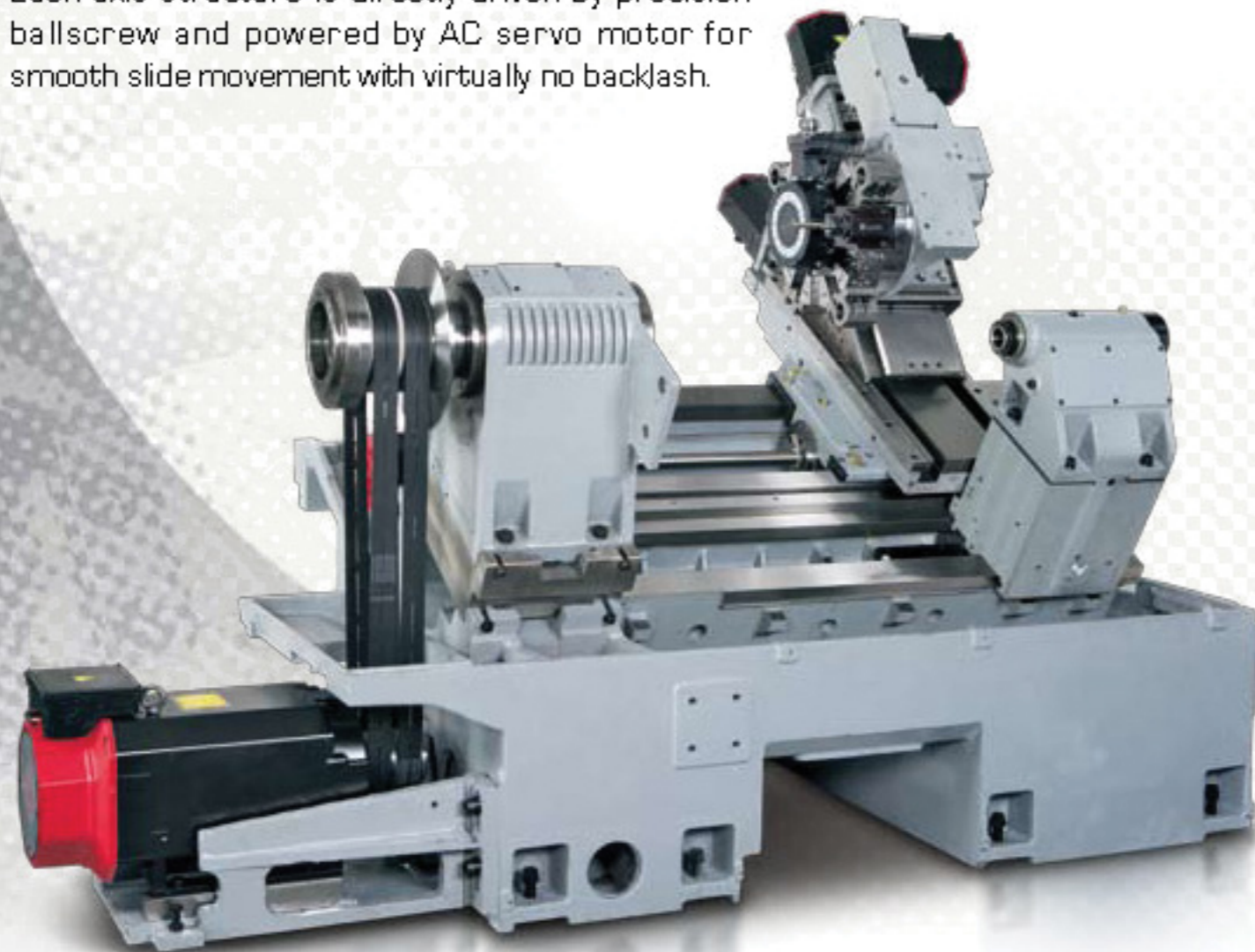

Multi-tasking Systems

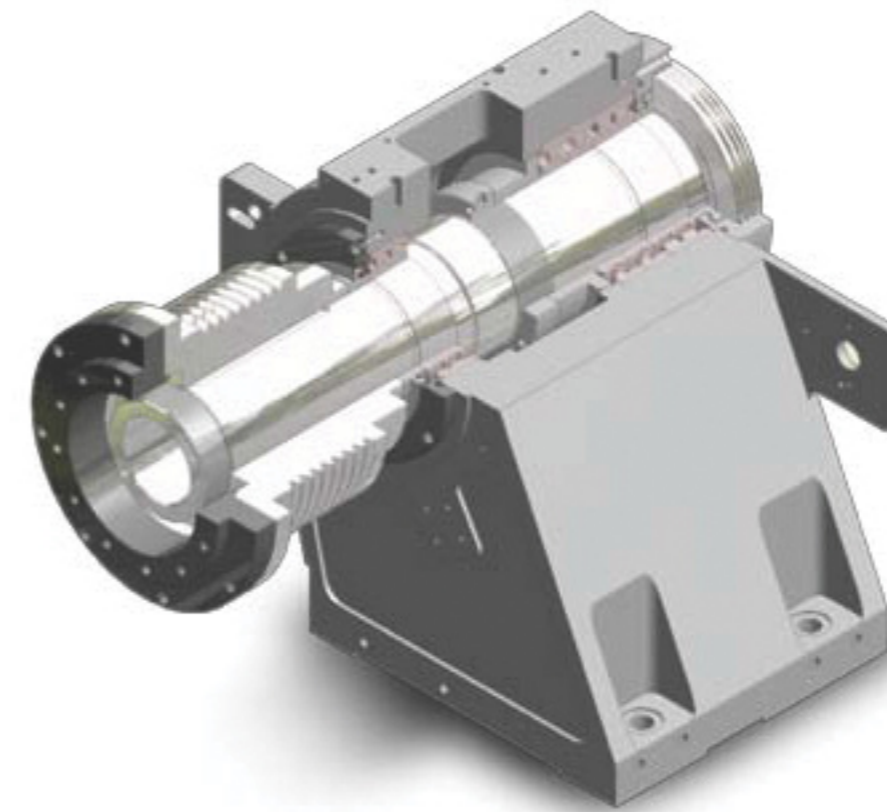

Spindle

- The thermally symmetrical design on the head stock diminishes distortion and provides stable accuracy on work pieces even in continuous high speed machining. The spindle is supported by a double row of tapered roller bearings in the front and rear of the spindle to resist axial cutting force, while self-alignment angular contact bearings provide tremendous radial load capability.

Main and Sub Spindles Synchronization

- Available on both the main spindle and sub-spindles, C1 and C2 axes provide positioning resolution up to 0.015 degree to accomplish three dimensional contouring, combined round and prismatic machining by harmonized control of the spindles with the X and Z axes. Exact synchronization between the main spindle and sub spindle at any rotation speed can be programmed to perform part transfer for secondary machining to enhance production efficiency and reduces idle time.

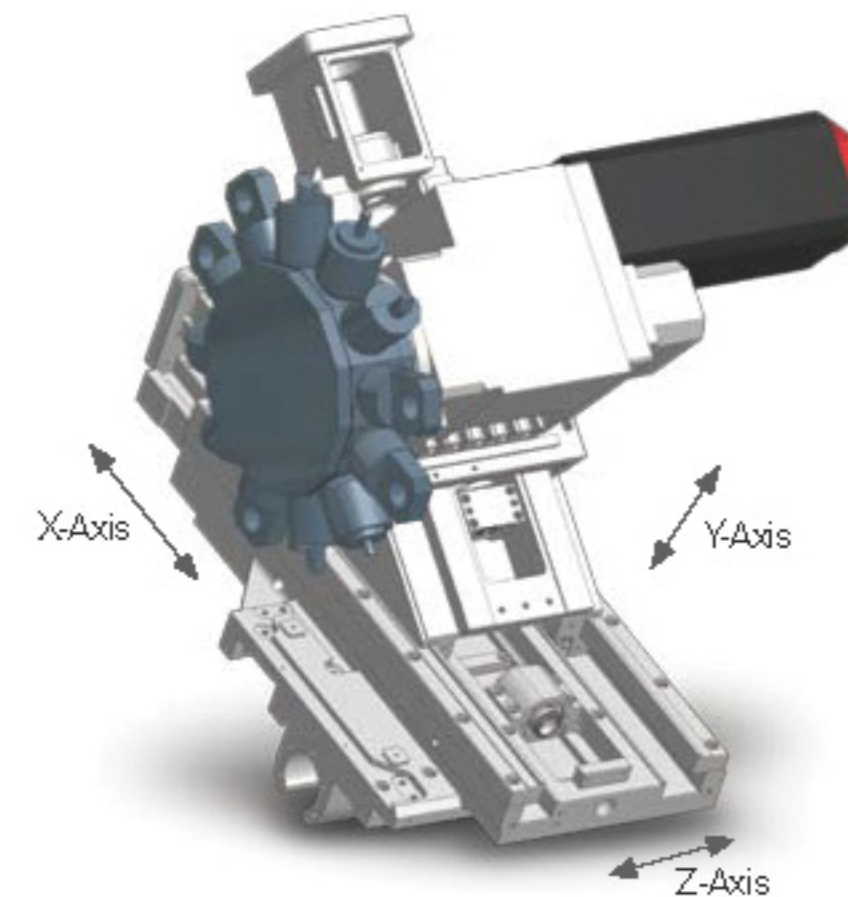
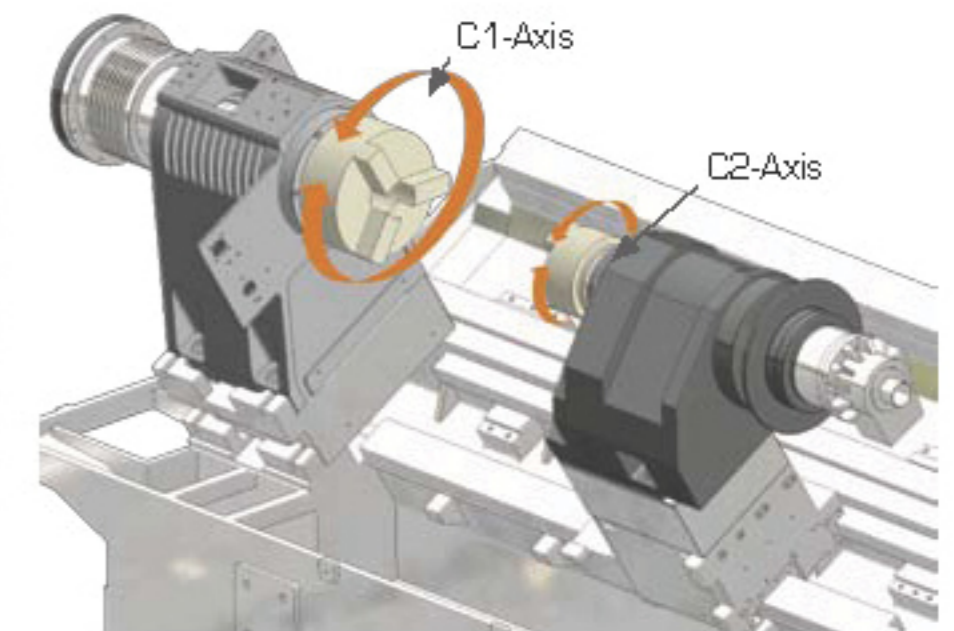

Y-axis

- Y-axis with +/- 50 mm of stroke is available for performing thread milling, complex off-center milling and drilling operations on the main or sub-spindle by combining live tool turret. The Y-axis travel is achieved by the simultaneous movement of the two independent slides. This design distributes cutting force over the two slides assuring exceptional rigidity and maximum accuracy.

Turning and Milling



VDI Power turret

Turret

The fast 12-station servo-mechanical dodecagonal drum turret, featuring a large 3-piece curvic coupling and powerful hydraulic clamping force, assures unparalleled rigidity in all machining conditions. Live tool holders can be mounted on all 12 stations, but only the working position is driven. VDI live tool turret is also available as an option upon request.

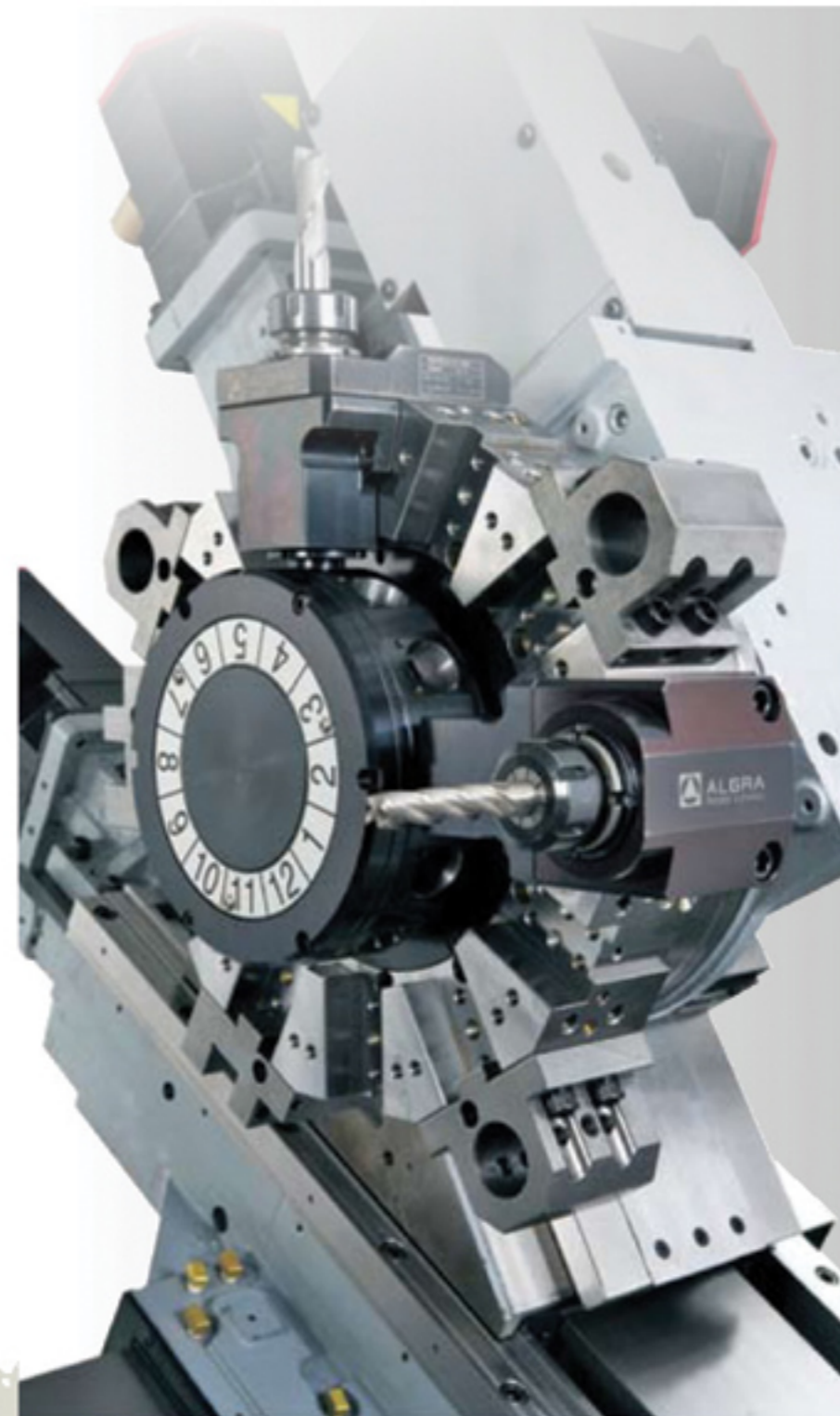

Dodecagonal Power turret

FANUC 18i-TB controller

10.4" color LCD plus manual guide i enable user to program complex components in multi-axis system.



Tooling System

UT-200S/UT-200SM

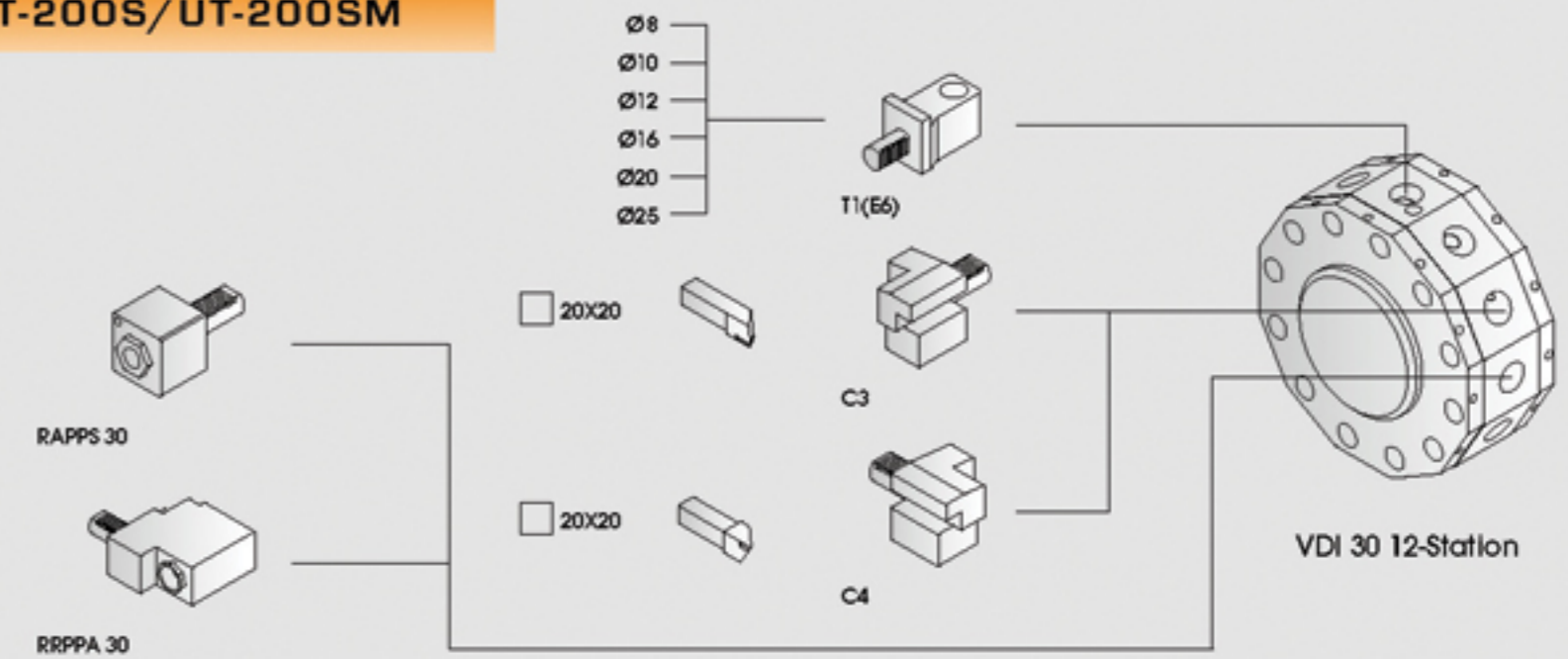

UT-300Y/UT-300LY

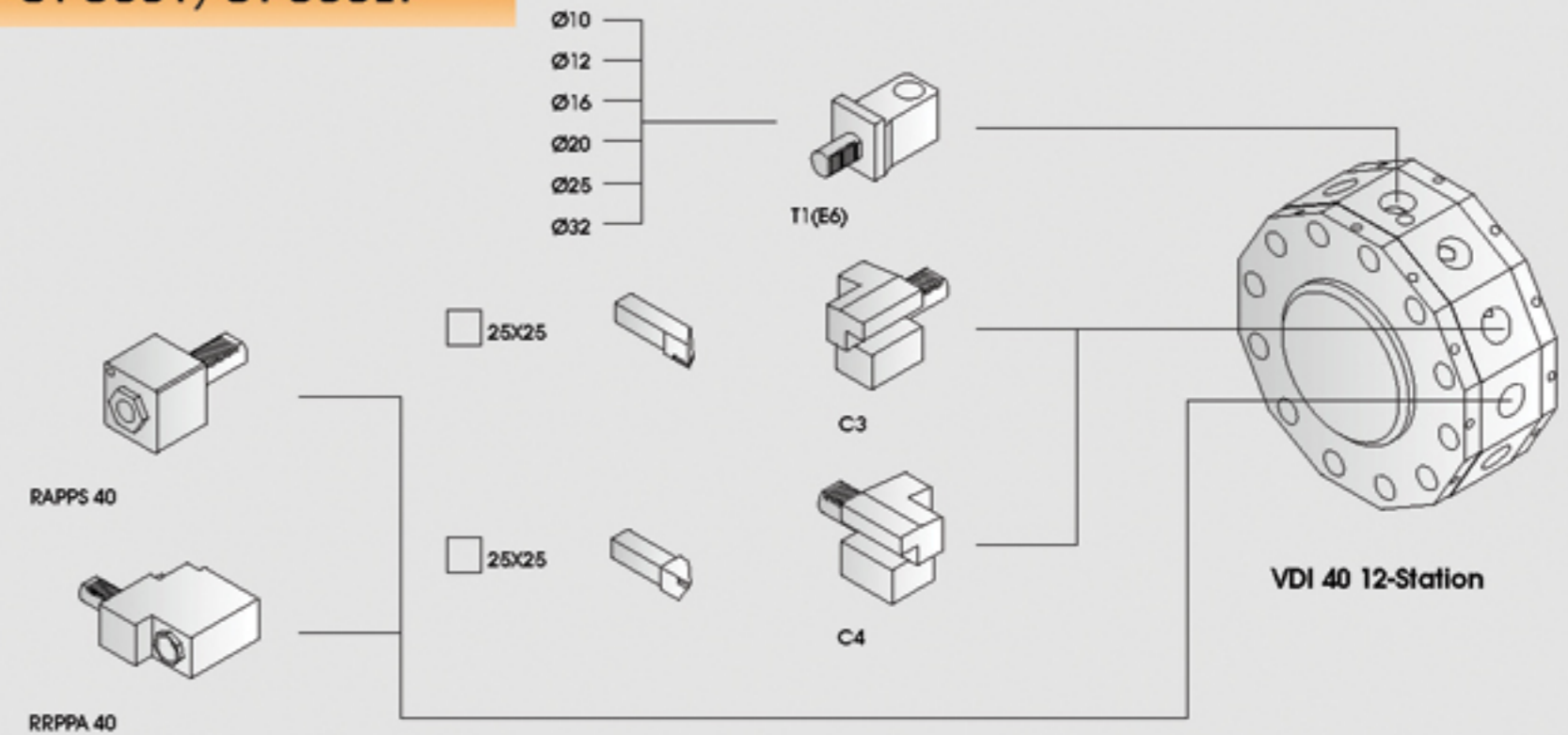

UT-300Y/UT-300LY

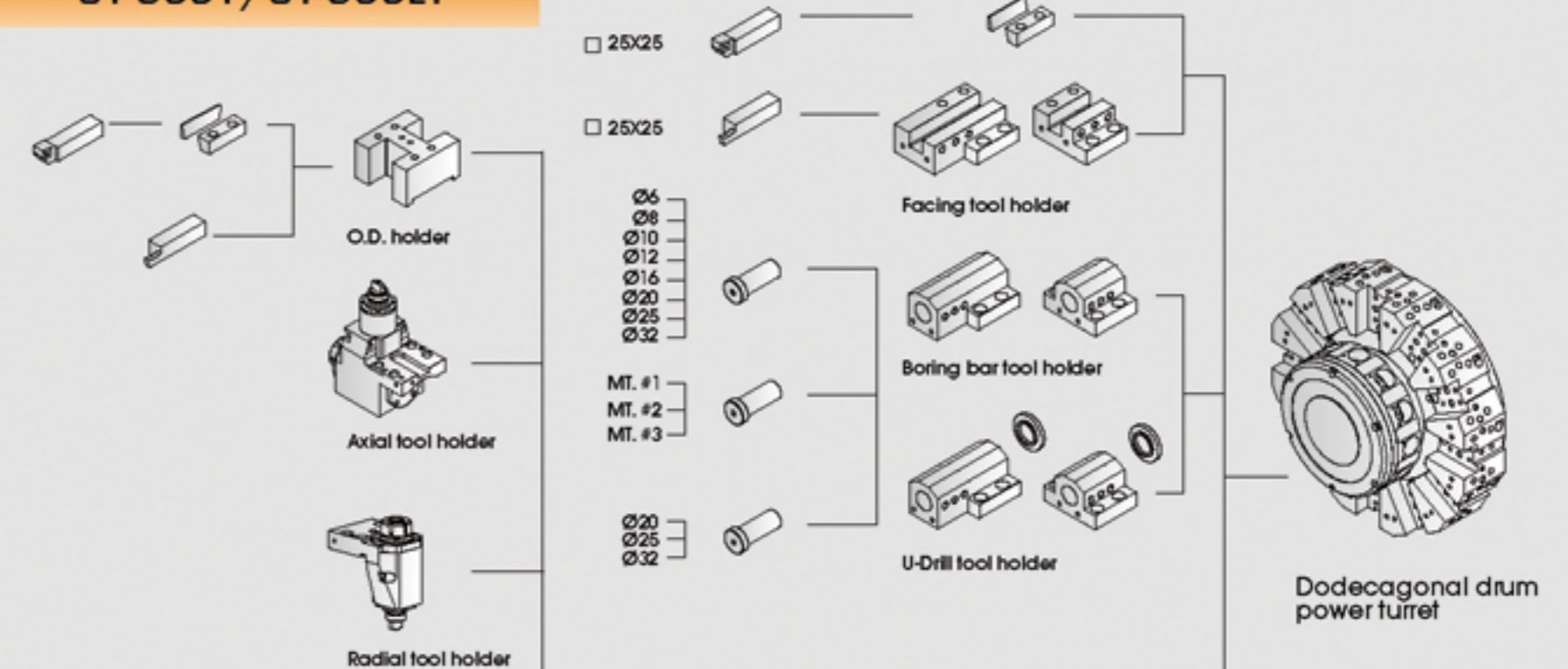

Working Range

UT-200SM

VDI 30 12-station power turret

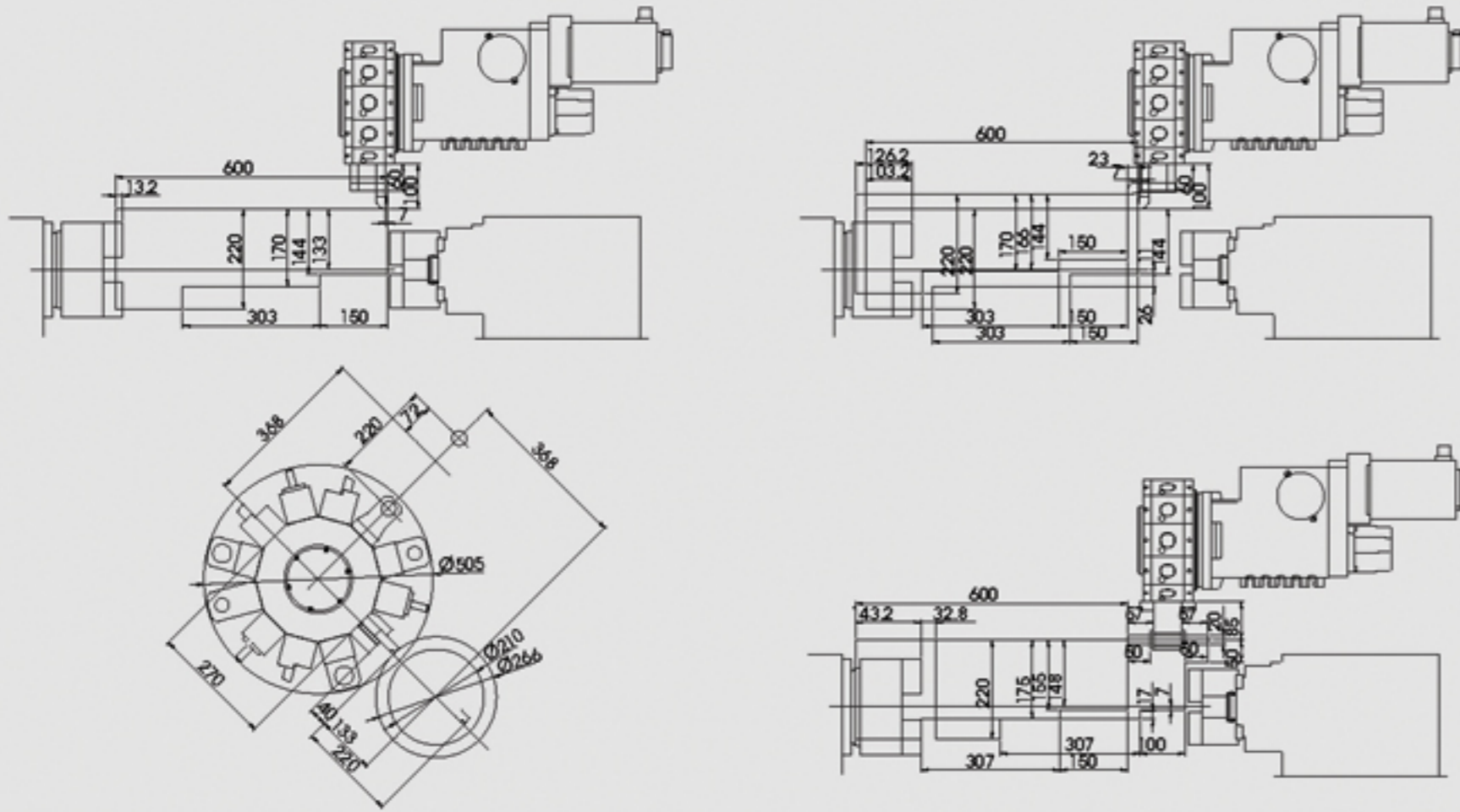

UT-300Y/UT-300LY

VDI 40 12-station power turret

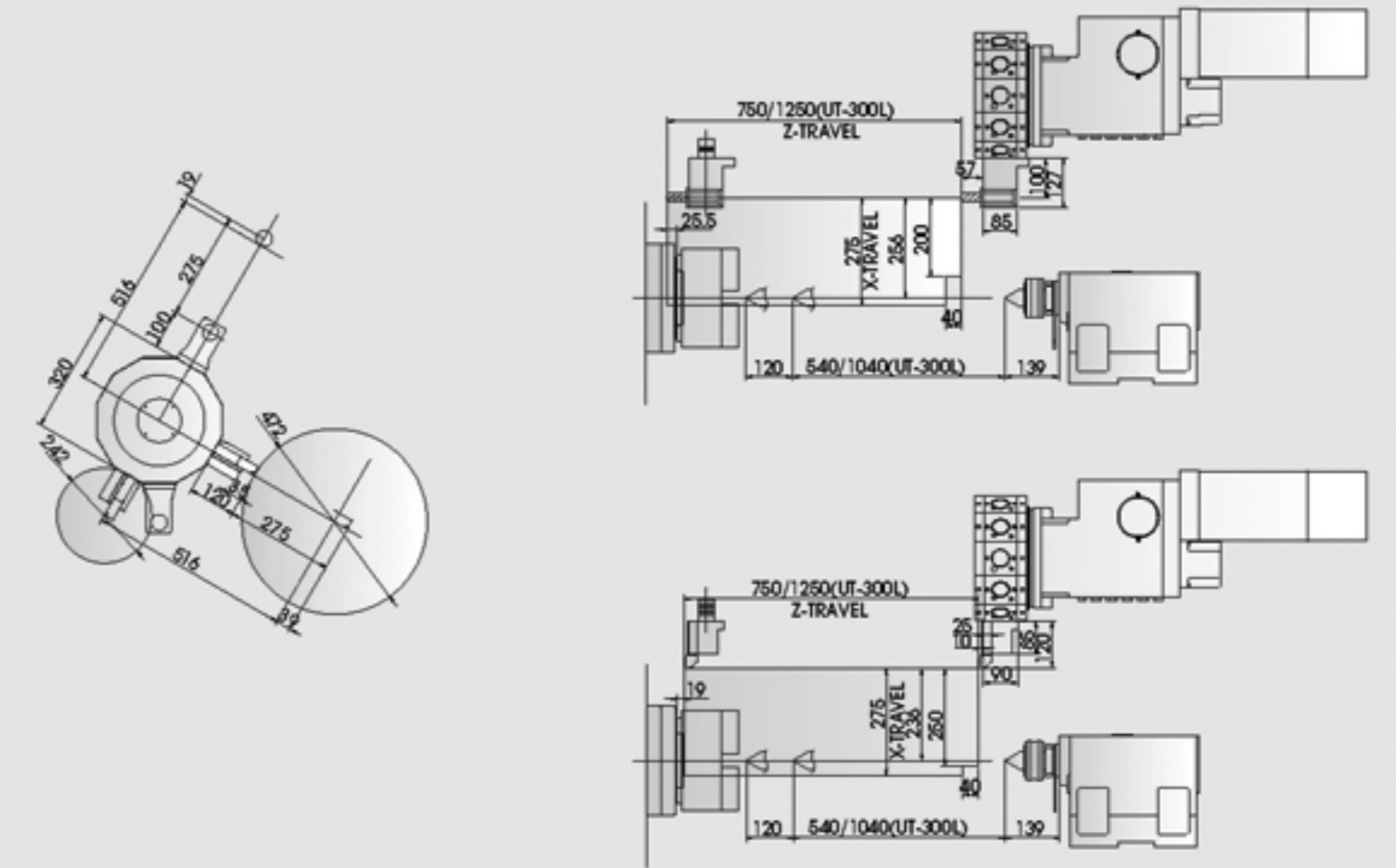

UT-300SM

VDI 40 12-station power turret

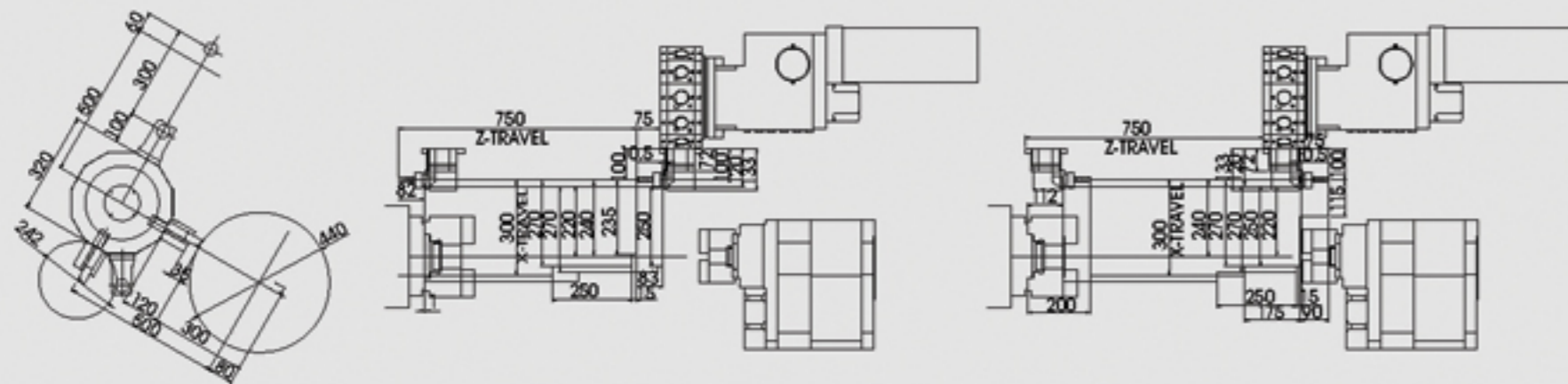

UT-300Y/UT-300LY

Dodecagonal drum power turret

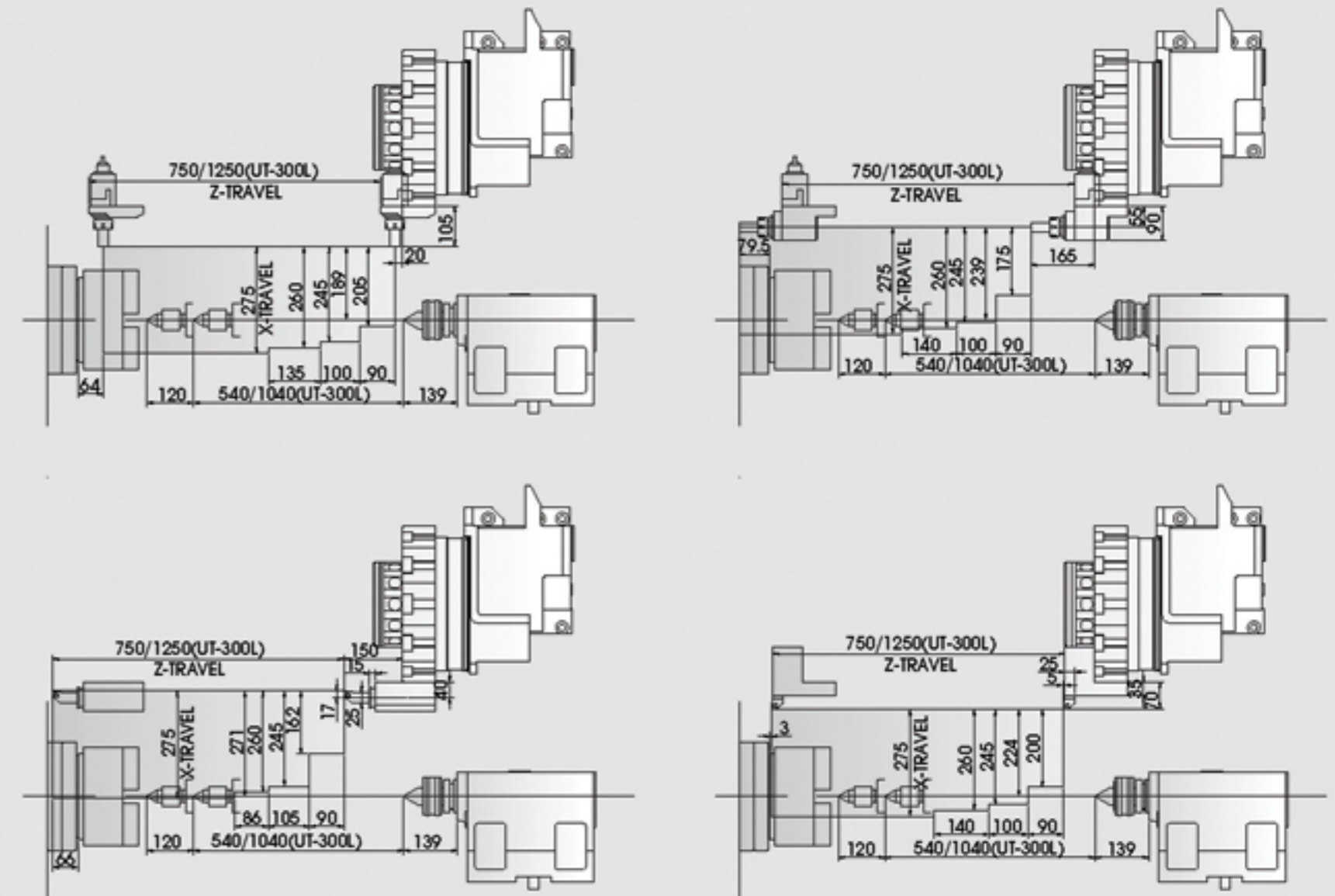

UT-300SM

Dodecagonal drum power turret

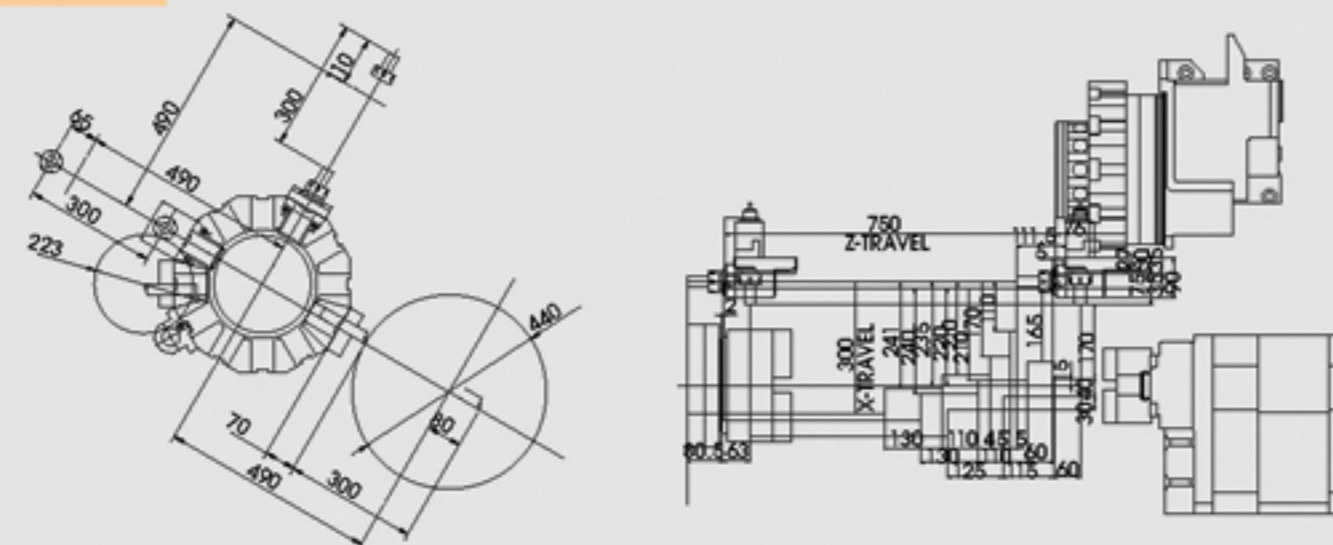

UT-200 Specification

Machine Model	UT-200S		UT-200SM	
Controller	FANUC 0iTC		FANUC 18iTB	
CAPACITY				
Swing over "Z" cover	mm	522	522	
Swing over "X" cover	mm	318	318	
Max cutting diameter (Main spindle)	mm	260	286	
Max cutting diameter (Sub-spindle)	mm	260	286	
Max cutting length	mm	495	495	
MAIN SPINDLE				
Spindle nose	ASA	A 2-6		A 2-6
Spindle bearing inner diameter	mm	100	110	100 110
Power chuck diameter	inch	8		8
Spindle hole diameter	mm	62	76	62 76
Spindle speed	rpm	4500	4000	4500 4000
Spindle drive (AC-30min rating)	KW	[α P22]11/15		[α P22]11/15
Bar capacity	mm	52	65	52 65
SUBSPINDLE				
Spindle nose	ASA	A 2-5		A 2-5
Power chuck diameter	inch	6		6
Spindle hole diameter	mm	56		56
Spindle speed	rpm	6000		6000
Spindle drive (AC-30min rating)	KW	[α B112M]5.5/7.5		[α B112M]5.5/7.5
Bar capacity	mm	45		45
TRAVELS				
Z axis	mm	600		600
X axis	mm	220		220
B axis	mm	625		625
FEEDS				
Rapid traverse- Z axis	m/min	20		20
Rapid traverse- X axis	m/min	20		20
Rapid traverse- B axis	m/min	20		20
TOOL TURRET				
Type		Hydraulic		Servo-mechanical
Number of tools	units	12 (VDI 30)		12 (VDI 30)
Tool size square(Machining the face)	mm	20		20
Tool size square(Machining the back)	mm	20		20
Tool size boring bar	mm	32		32
Cs spindle index angle	degree	-		0.015
Max. rotary tool speed	rpm	-		6000
Rotary tool driver power	kW	-		2.2
DIMENSIONS				
Floor space required	M	2.9 x 1.6		2.9 x 1.6
Height	M	1.7		1.7
Weight	kg	4000		4000

UT-300 Specification

Machine Model	UT-300Y		UT-300LY		UT-300SM		UT-300SY	
Controller	FANUC 0iTC		FANUC 0iTC		FANUC 18iTB		FANUC 18iTB	
CAPACITY								
Swing over "Z" cover	mm	910	910		612		910	
Swing over "X" cover	mm	720	720		388		720	
Max cutting diameter (Main spindle)	mm	470	450		420		450	
Max cutting diameter (Sub-spindle)	mm	-	-		375		375	
Max cutting length	mm	615	1145		610		615	
MAIN SPINDLE								
Spindle nose	ASA	A2-8		A2-8	A2-11	A2-8		A2-8
Spindle bearing inner diameter	mm	130	140	130	140	160	130	140
Power chuck diameter	inch	10	12	10	12	15	10	12
Spindle hole diameter	mm	86	101	86	101	116	86	101
Spindle speed	rpm	3500	2700	3500	2700	2500	3500	2700
Spindle drive (AC-30min rating)	KW	[α P30] 15/18.5		[α P30] 15/18.5 [α P40] 18.5/22		[α P30] 15/18.5		[α P30] 15/18.5
Bar capacity	mm	75	90	75	90	105	75	90
SUBSPINDLE								
Spindle nose	ASA	-		-	A2-5		A2-5	
Power chuck diameter	inch	-		-	6		6	
Spindle hole diameter	mm	-		-	56		56	
Spindle speed	rpm	-		-	6000		6000	
Spindle drive (AC-30min rating)	KW	-		-	[α 112M]5.5/7.5		[α 112M]5.5/7.5	
Bar capacity	mm	-		-	45		45	
TRAVELS								
Z axis	mm	750		1250		750		750
Y axis	mm	± 50		± 50		-		± 50
X axis	mm	275		275		300		275
B axis	mm	-		-		780		660
FEEDS								
Rapid traverse- Z axis	m/min	24		24		24		24
Rapid traverse- Y axis	m/min	10		10		-		10
Rapid traverse- X axis	m/min	20		20		20		20
Rapid traverse- B axis	m/min	-		-		24		24
TOOL TURRET								
Type		Dodecagonal drum / VDI		Dodecagonal drum / VDI	Dodecagonal drum / VDI	Dodecagonal drum / VDI		Dodecagonal drum / VDI
Number of tools	station	12		12		12		12
Tool size square	mm	25		25		25		25
Tool size boring bar	mm	40		40		40		40
Cs spindle index angle	deg	0.015		0.015	0.001	0.015		0.015
Max. rotary tool speed	rpm	4000 / 5000		4000 / 5000		4000 / 5000		4000 / 5000
Rotary tool driver power	kW	3 / 3.7		3 / 3.7		3 / 3.7		3 / 3.7
TAILSTOCK								
Tailstock body travel	mm	540		1040		-		-
Quill travel	mm	120		120		-		-
Quill diameter	mm	85		85		-		-
Quill taper hole	MT	5		5		-		-
Tailstock body positioning		Programmable		Programmable		-		-
DIMENSIONS								
Floor space required	M	3.5 X 2		3.6 X 2		3 X 1.8		3.5 X 2
Height	M	2.2		2.2		1.8		2.2
Weight	kg	6000		7500		5900		6500

ACCUWAY

AGENT:



Y A M A R I S
MACHINERY PTE LTD

No. 15 Pioneer Sector 3, Singapore 628348
Tel: (65) 6862 9768 / 9627 0967 Fax: (65) 6862 8917
Email: yamaris@singnet.com.sg Website: www.yamaris.com.sg